



INSTALLATION INSTRUCTIONS

Accessory
ENGINE BLOCK HEATER
P/N 08T44-TA0-100

Application
2015 CIVIC
2 AND 4-DOOR Si

Publications No.
VERSION 1
Issue Date
SEP 2014

PARTS LIST

Engine block heater

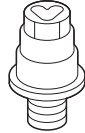

Aluminum washer



Heater harness

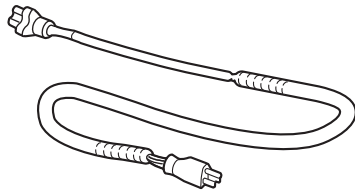

Protective cap

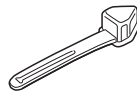

12 Black wire ties
(1 Not used)

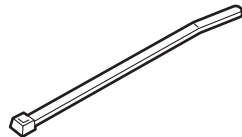

7 Wire ties with clip
(Not used)

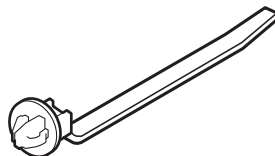

5 Wire ties (Natural)
(3 Not used)

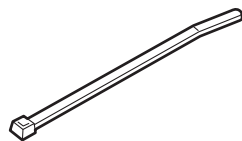

Coolant concentration label



TOOLS AND SUPPLIES REQUIRED

Phillips screwdriver

Flat-tip screwdriver

Ratchet

10 mm, 12 mm, 16 mm, and 24 mm Sockets

Torque wrench

Diagonal cutters

Heavy gloves

Drain pan

Tape measure

White marker

Coolant (Honda All-Season Antifreeze/Coolant Type 2)

Eye protection (face shield, safety goggles, etc.)

Blanket

Drill

3 mm and 5 mm Drill bits

5 mm and 10 mm Hex wrenches

Pushpin

Fender cover

Tape

Shop towel

Masking tape

File

The following tool is available through the Honda Tool and Equipment Program. On the iN, click on: Service > Service Bay > Tool and Equipment Program, then enter the number under "Search". Or, call 888-424-6857.

- Trim Tool Set (T/N SOJATP2014)

Illustration of the Engine Block Heater on the Vehicle

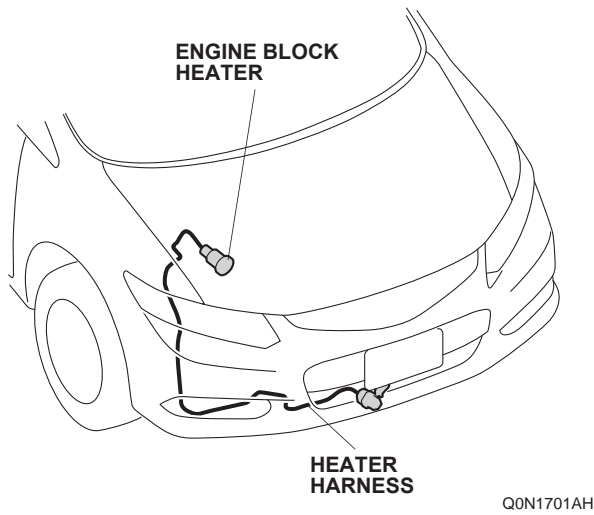

INSTALLATION

Customer Information: The information in this installation instruction is intended for use only by skilled technicians who have the proper tools, equipment, and training to correctly and safely add equipment to your vehicle. These procedures should not be attempted by “do-it-yourselfers.”

NOTE:

- Always use Honda All-Season Antifreeze/Coolant Type 2. Using a non-Honda coolant can result in corrosion, causing the cooling system to malfunction or fail.
 - To avoid burning out the element, do not operate the engine block heater until it is installed in the vehicle and you have added the coolant.
 - Follow steps 37 through 39 and increase the concentration rate of coolant to 60 ± 2%.
1. Disconnect the negative cable from the battery.
 2. Allow the engine and all cooling system components to cool down.

3. Place a clean drain pan under the radiator drain plug, then remove the drain plug from the bottom of the radiator to drain the coolant. Remove the radiator cap to increase the flow.

NOTICE: Radiator coolant will damage the paint. Quickly rinse any spilled coolant from the paint.

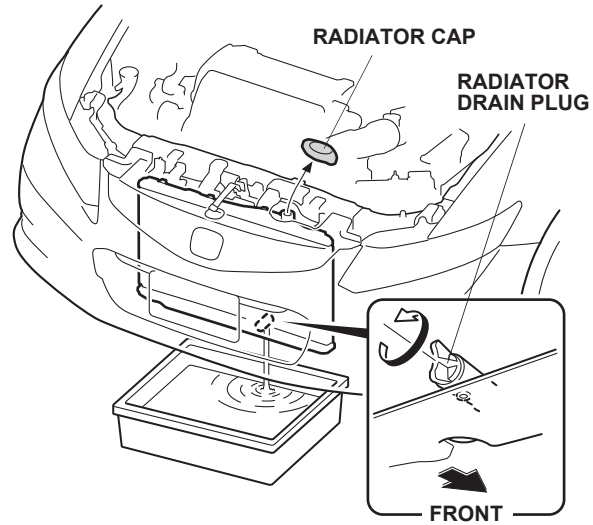

4. Drain the coolant completely, then reinstall the radiator cap.
5. Attach masking tape to the windshield below each wiper blade as shown.

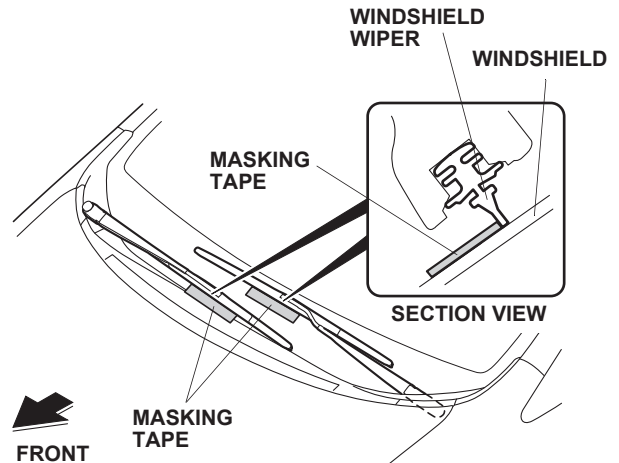

6. Open the hood, and remove the right wiper cover.

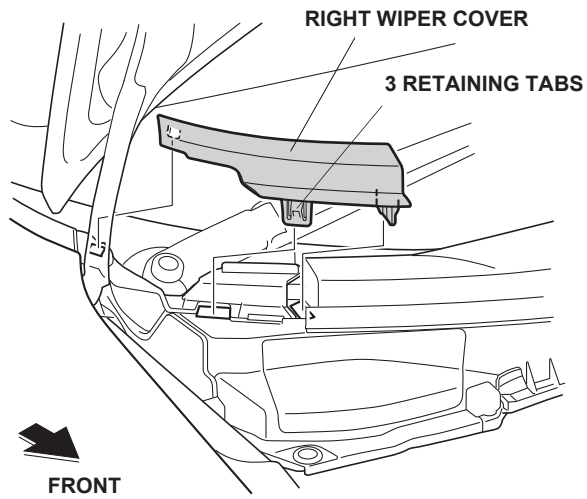

Q070604BH

7. Remove the left wiper cover.

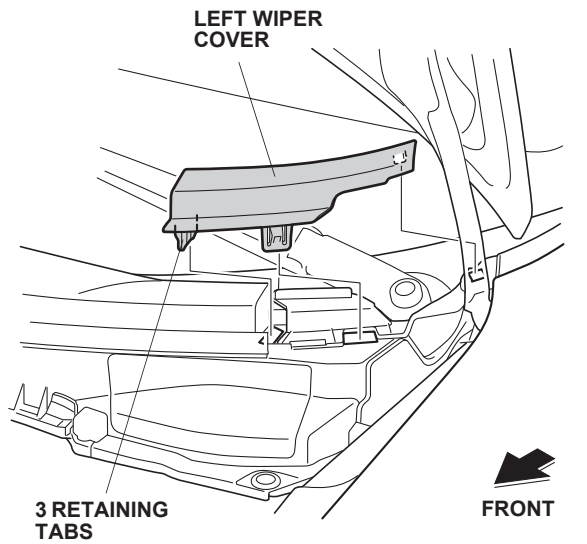

Q070603BH

8. Close the hood, and remove the left windshield wiper arm.

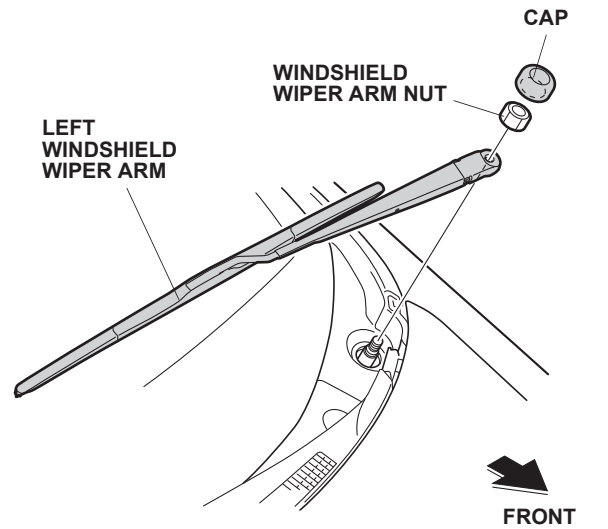

Q070601BH

9. Remove the right windshield wiper arm.

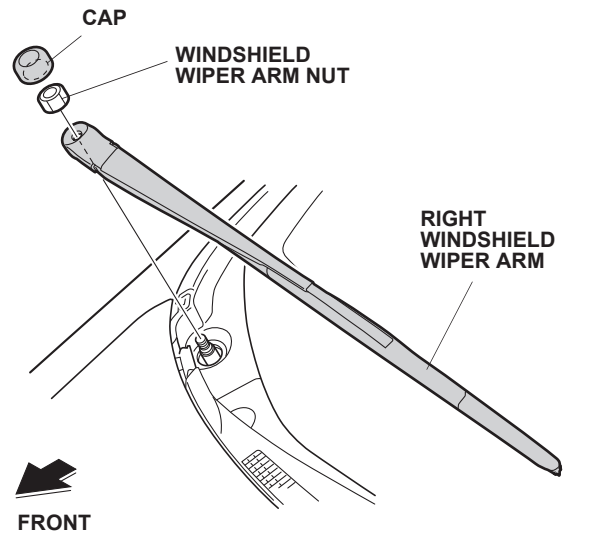

Q070602BH

10. Open the hood, and remove the right cowl cover.

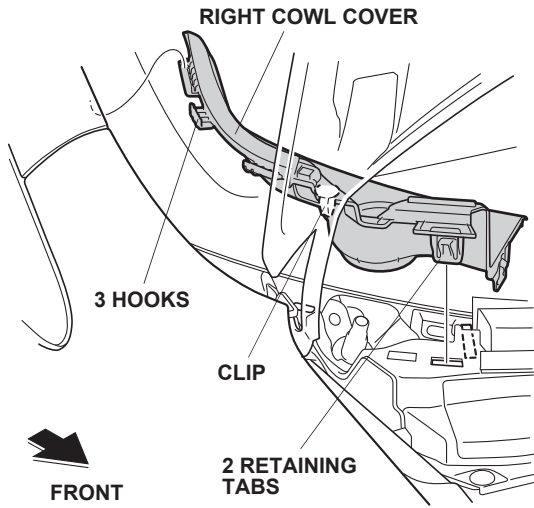

Q070606AH

11. Remove the left cowl cover.

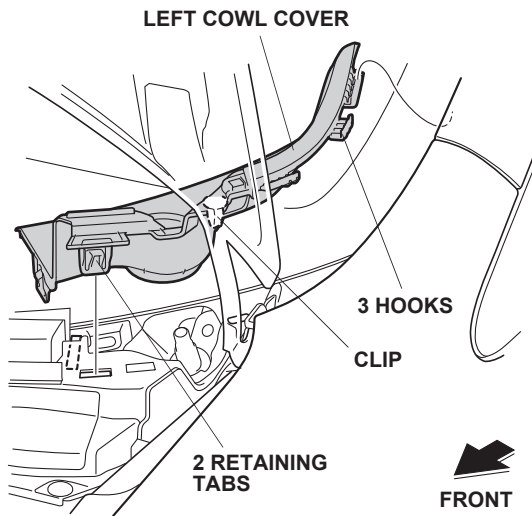

Q070605AH

12. Remove the cover, and the center cowl cover.

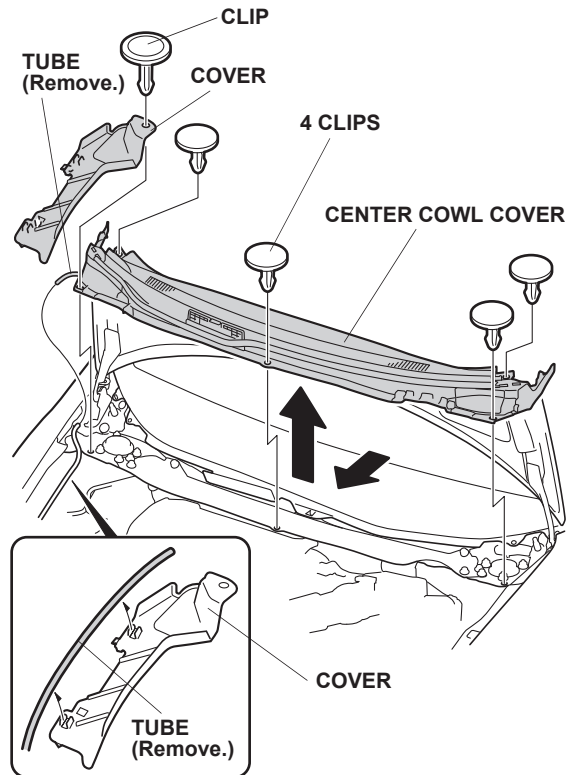

Q0N1703BH

13. Remove the under cowl panel.

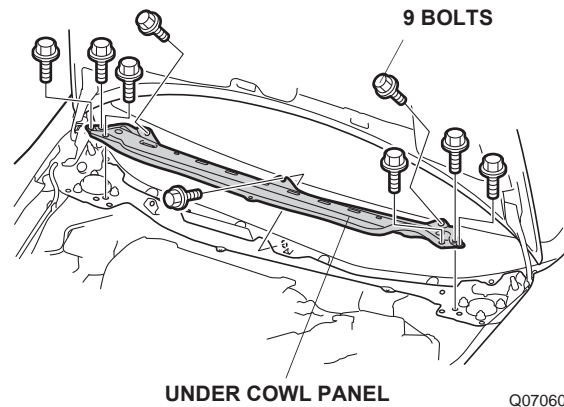

Q070609BH

14. Remove the front bumper:

- On each side, attach tape to the areas shown.
- Wrap a shop towel around the hood latch.

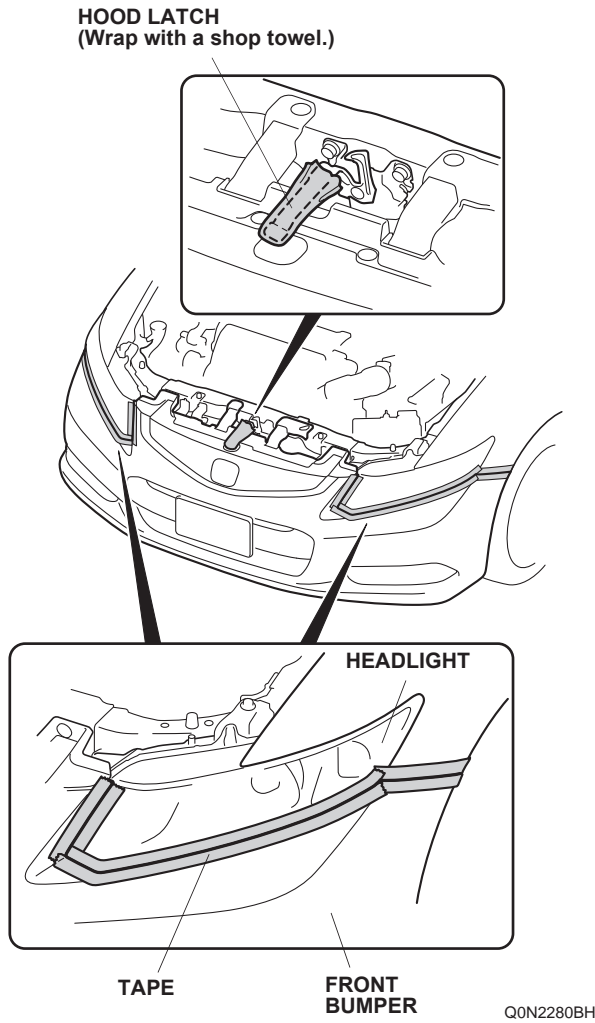

- Remove the four self-tapping screws, ten short clips, and two long clips.

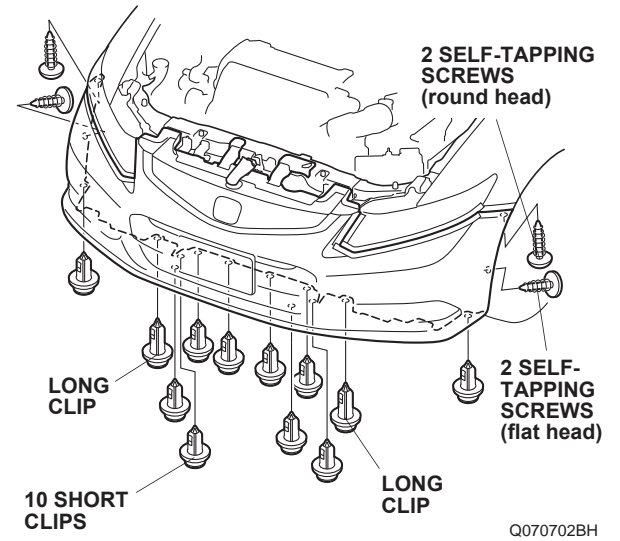

- On each side, release three retaining tabs.

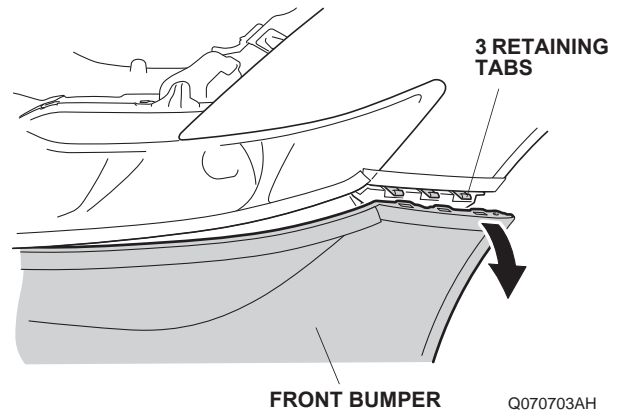

- On each side, release five retaining tabs.

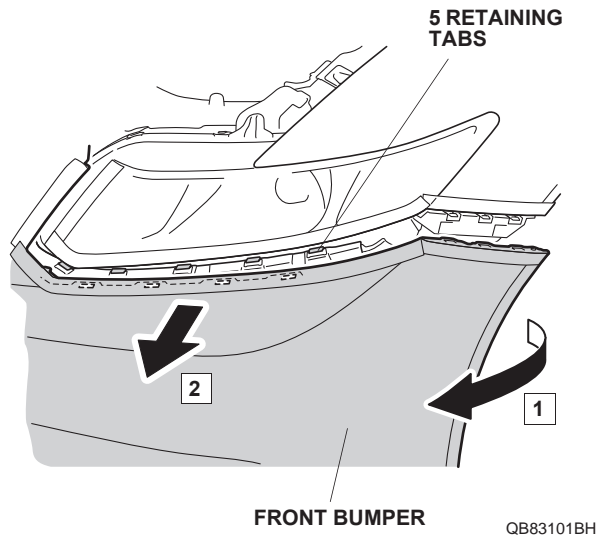

- With the help of an assistant, remove the front bumper and unplug the vehicle connectors. Place the front bumper on a blanket to prevent damage.

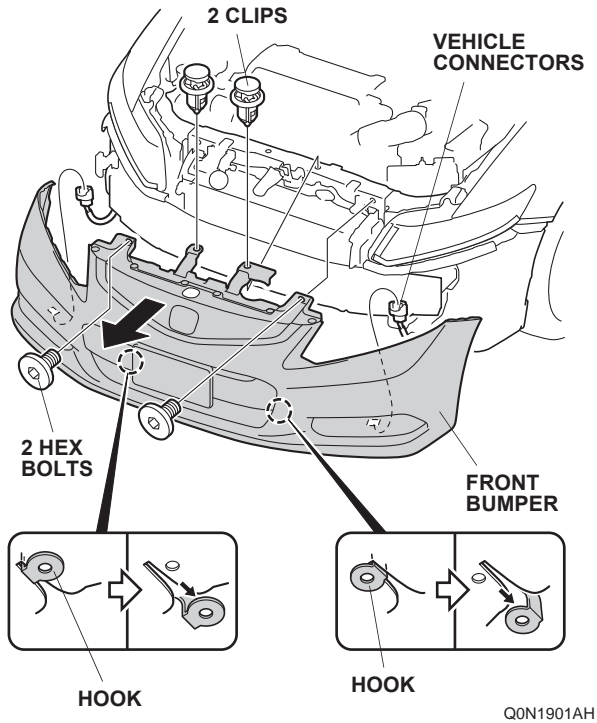

- Get the heater harness. Using a tape measure, measure and mark the heater harness at the measurements A, B, and C.

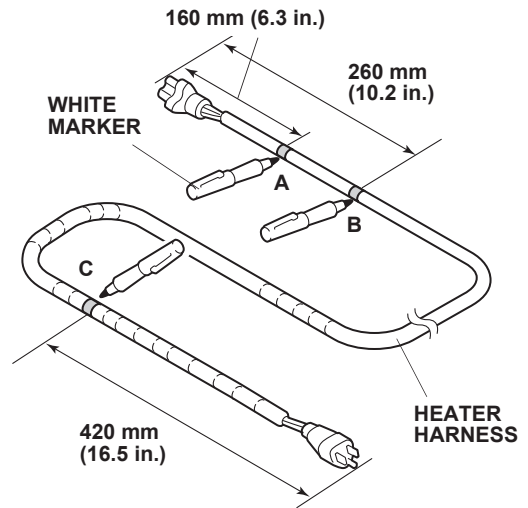

16. Locate and remove the drain bolt. Coolant remaining in the engine jackets flows out of the hole when the bolt is removed. Retain the bolt; it will be used if the block heater is removed.

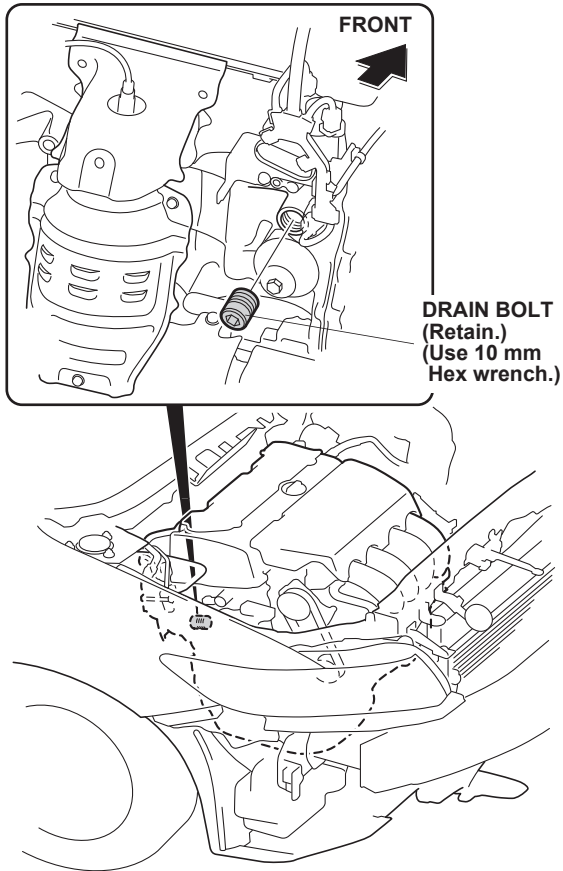

Q082101AH

17. Install the engine block heater with aluminum washer into the bolt hole using a 24 mm socket and a torque wrench. Torque the engine block heater to 85 N·m (63 lbf·ft).

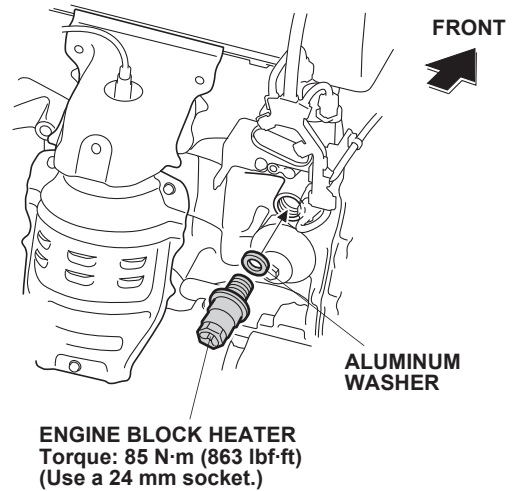

Q082102AH

18. Plug the connector end of the heater harness into the engine block heater. Make sure the heater harness connector is fully seated in the engine block heater.

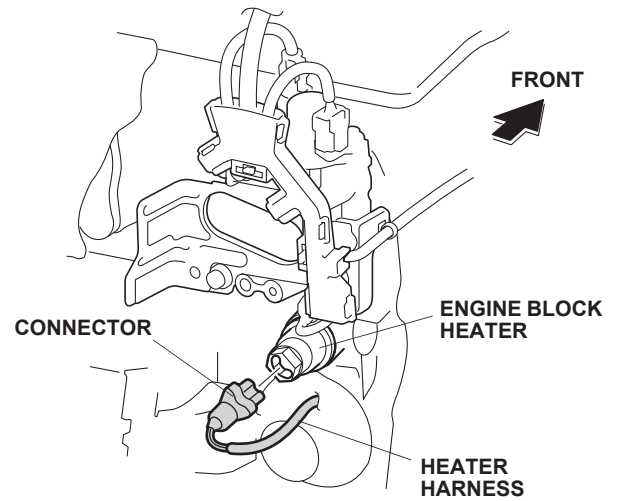

Q082103AH

19. Secure the heater harness to the vehicle bracket with one wire tie at the white mark (point A).

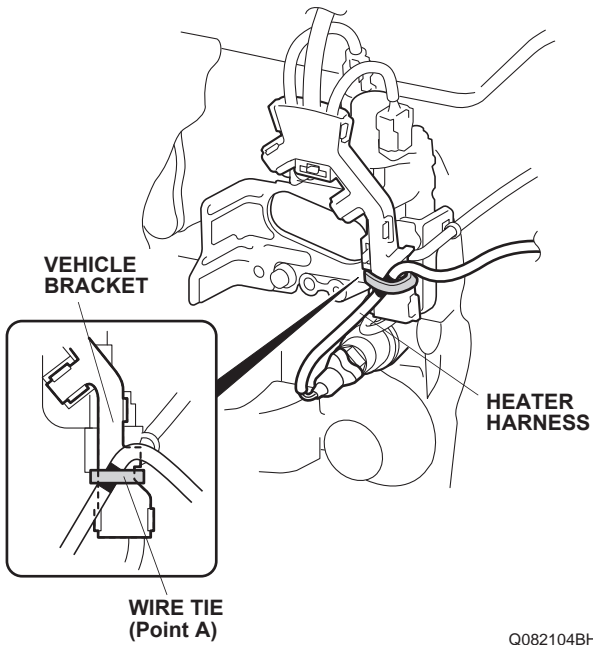

20. Route the heater harness as shown. Secure the heater harness to the vehicle harness with one wire tie at the white mark (point B).

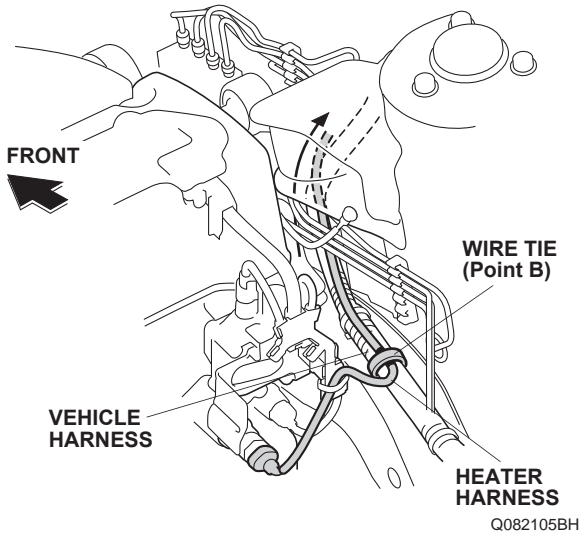

21. Remove the clip from the washer reservoir, and move the reservoir out of the way.

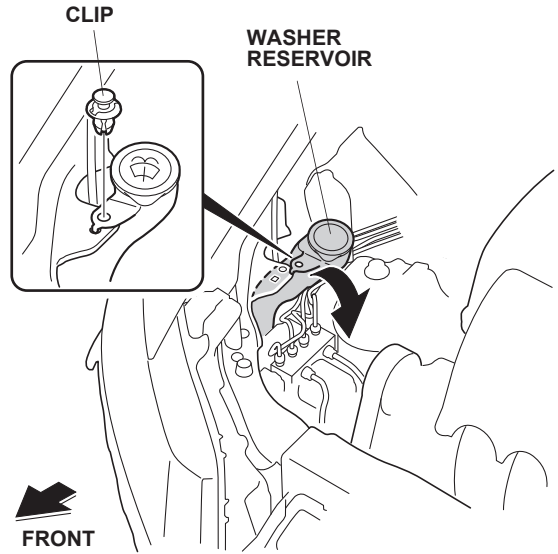

22. Route the heater harness forward along the vehicle harness, behind the washer reservoir, through the front bulkhead and under the right headlight.

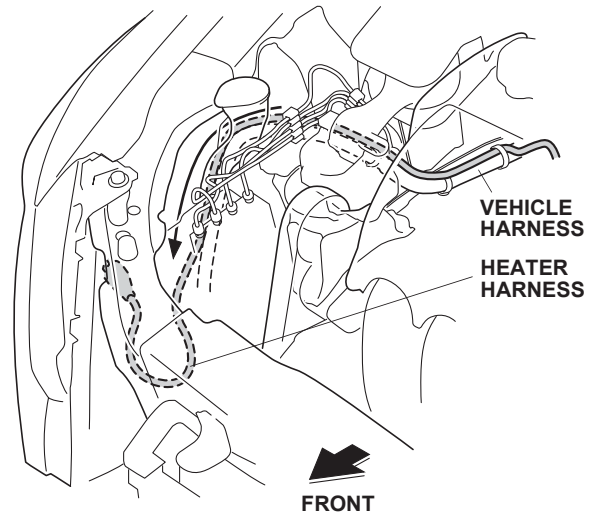

23. Using four black wire ties, secure the heater harness to the vehicle harness in the areas shown.

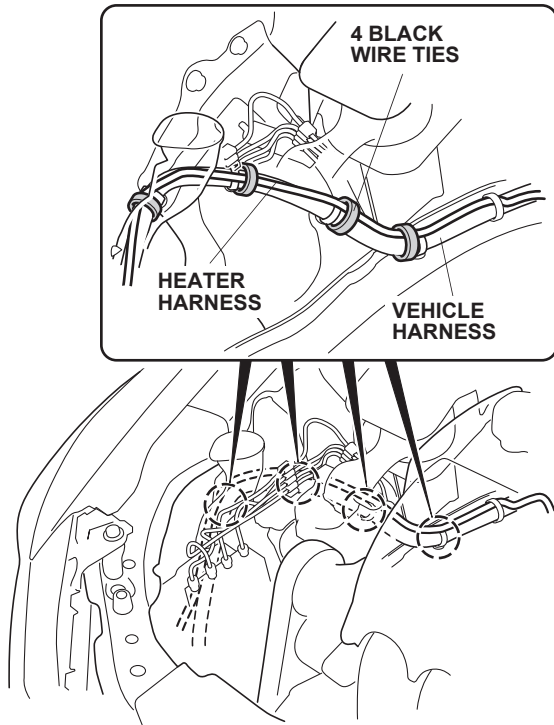

Q082108AH

24. Pull the inner fender away from washer reservoir, then route the heater harness as shown.

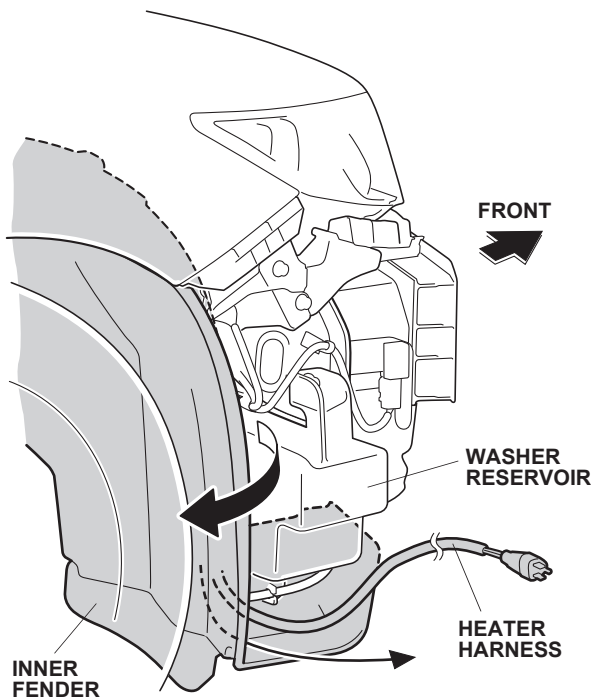

Q0N1705AH

25. Using two black wire ties, secure the heater harness to the vehicle harness as shown.

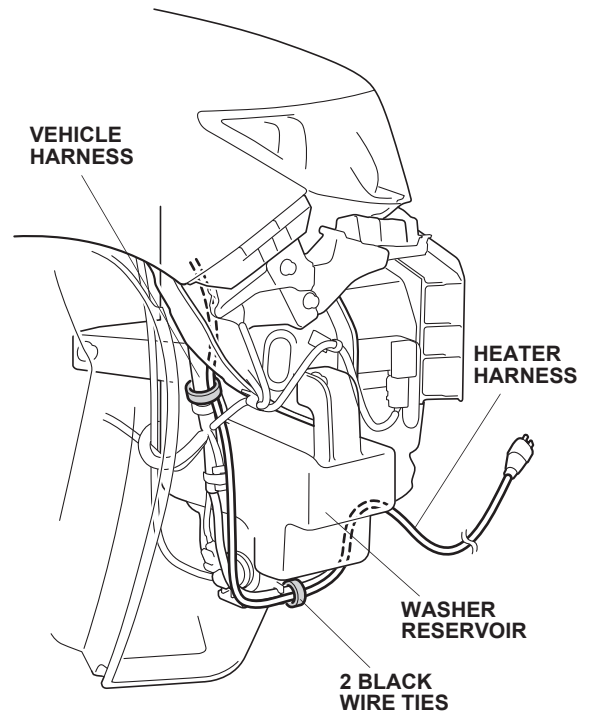

Q082110AH

26. Using one black wire tie, secure the heater harness to the vehicle harness.

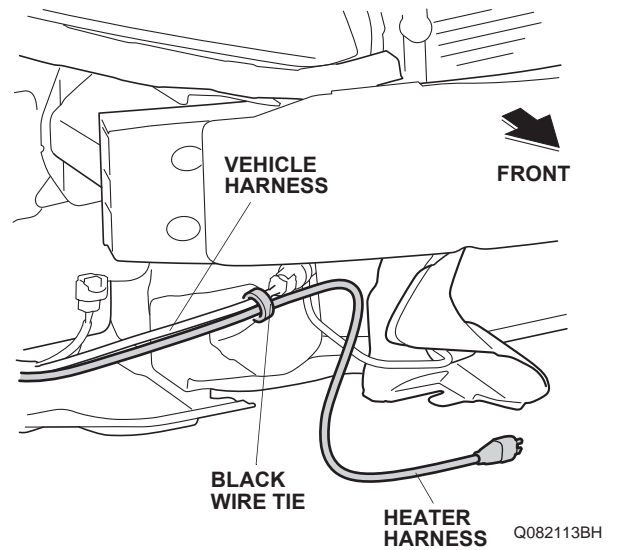

Q082113BH

27. Using a white marker, mark the vehicle panel at the measurements shown.

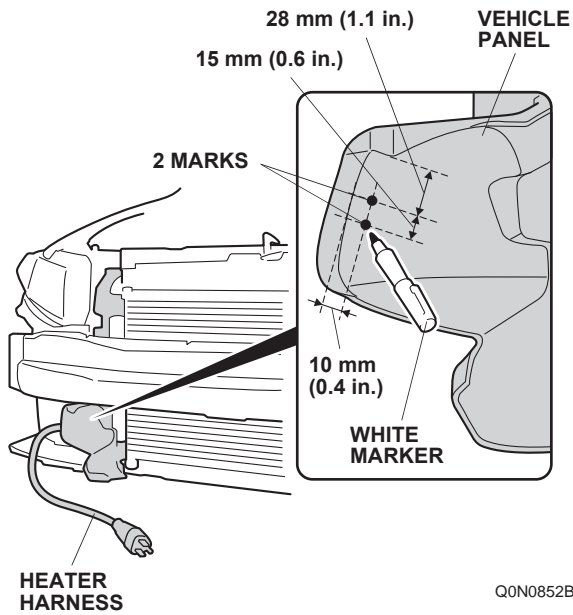

28. Using a pushpin, pierce the two marks you made into the vehicle panel at the location shown. While wearing eye protection, drill the two pierced marks with a 3 mm drill bit, then enlarge the holes with a 5 mm drill bit as shown. Remove any burrs.

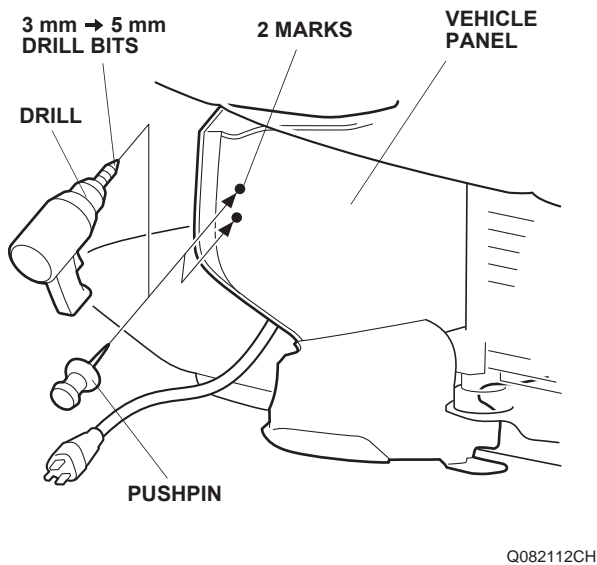

29. Secure the heater harness to the two 5 mm holes in the vehicle panel with one black wire tie at the white mark (point C).

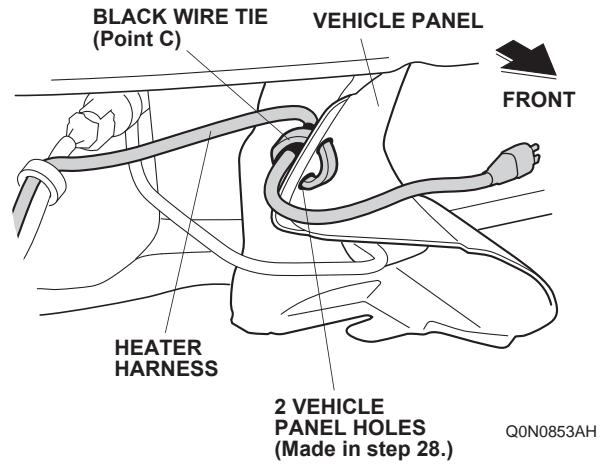

30. Route the heater harness through the front bumper as shown, then reinstall the front bumper with the help of an assistant.

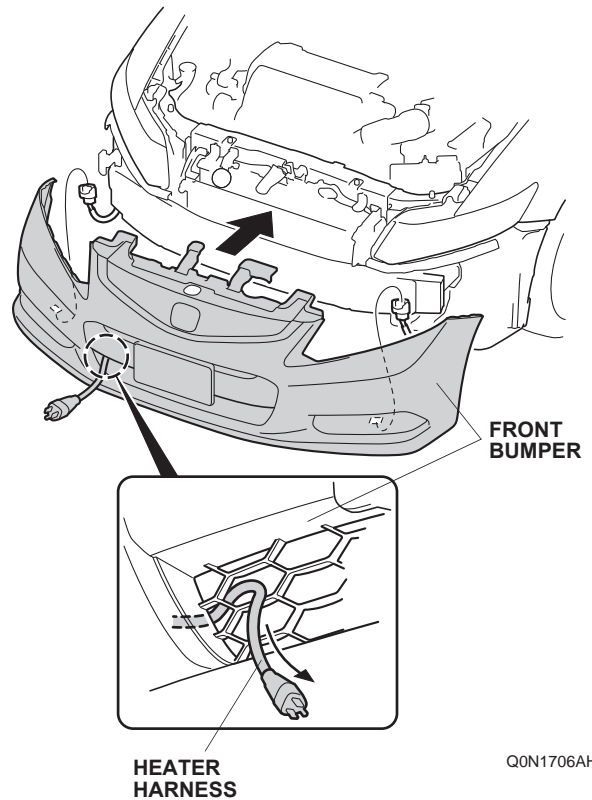

31. Using one black wire tie, secure the heater harness to the front bumper.

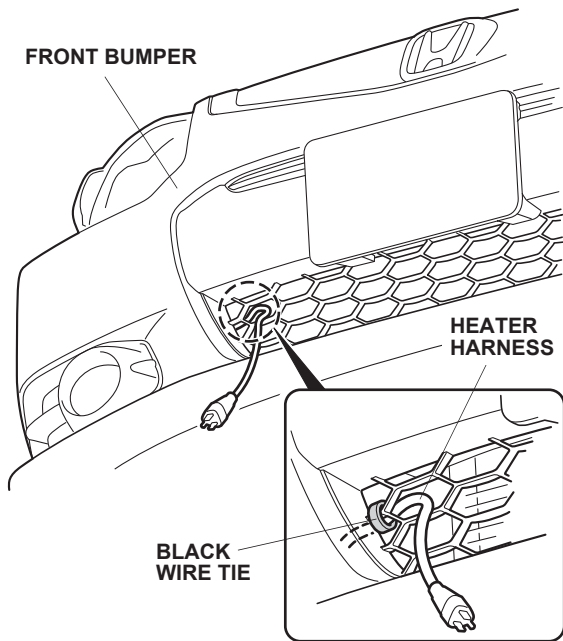

Q0N1707AH

32. Route the heater harness inside the front bumper as shown.

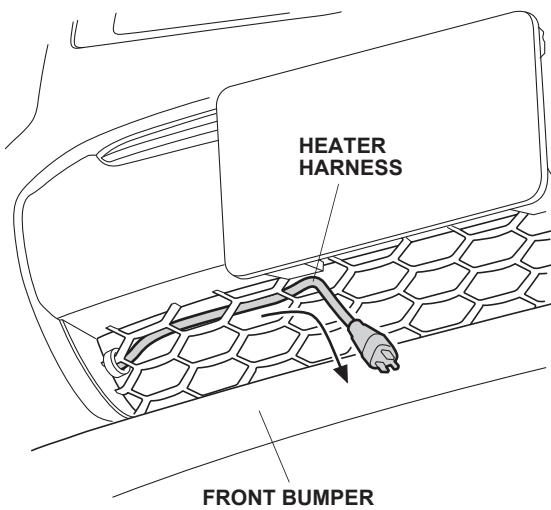

Q0N1708AH

33. Using two black wire ties, secure the heater harness to the front bumper.

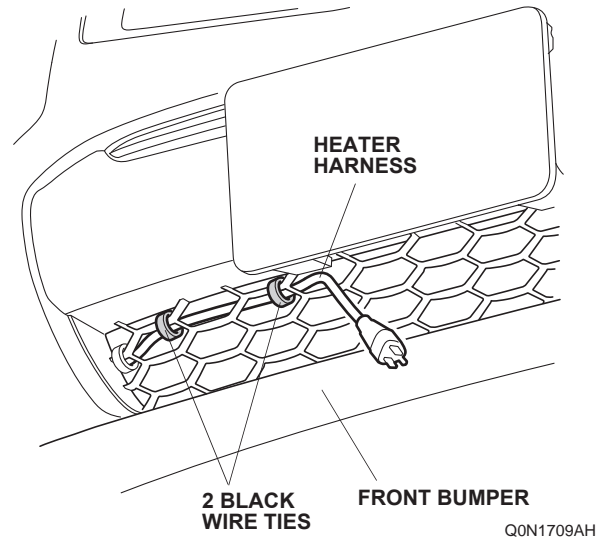

Q0N1709AH

34. Attach the protective cap to the front bumper, and plug the heater harness connector into the protective cap.

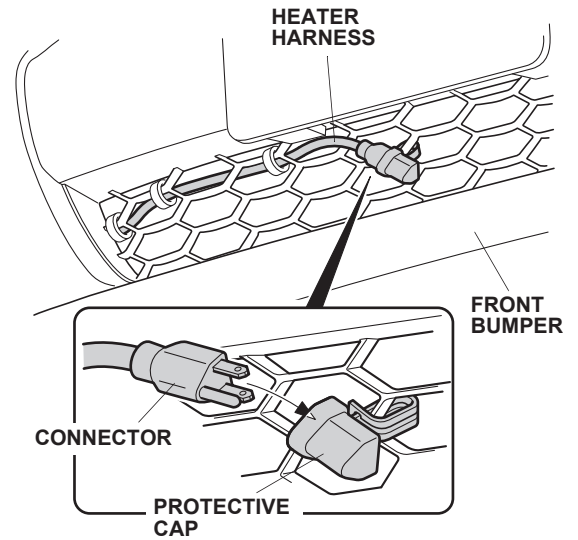

Q0N1710AH

35. Reinstall all removed parts except for the radiator cap. Torque the windshield wiper arm nuts to 30 N·m (22 lbf·ft).
36. Reinstall the radiator drain plug.
37. Pour 1.3 liters of the 100% concentration coolant through the radiator filler port.
38. Pour the 50% concentration coolant up to the top of the radiator filler port.
39. Fill the system with the recommended coolant. Follow the instructions in the service manual to fill the cooling system and check for leaks. Particularly check that there is no leak around the engine block heater.
40. Install the coolant concentration label to the radiator as shown.

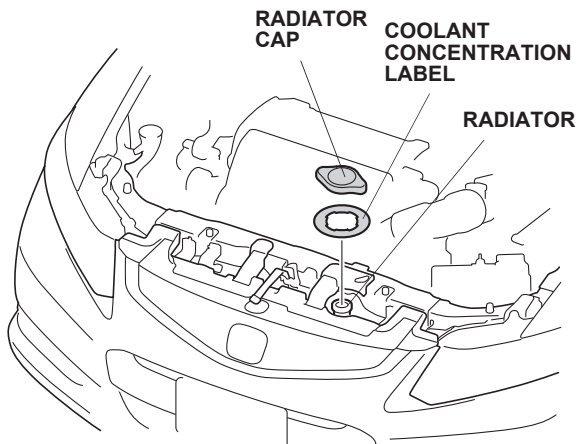

QB80821AH

41. Reinstall the radiator cap.
42. Make sure that the heater harness is routed properly and all connectors are plugged in.
43. Put the drain bolt (removed in step 16) in the glove box.
44. Reconnect the negative cable to the battery.
45. Press and hold the radio power button for two seconds to restore the radio and navi (if equipped) system functions.
46. Reset the clock.